



LAF Dry Bulk Liner

Dry Bulk Liner

Dry Bulk Liner, which is also called as Container liner, is widely used for 20ft/ 30ft/ 40ft ISO containers, suitable for bulk free-flowing granules and powders.

Dry Bulk Liner is made from food-grade materials to keep the goods dry and hygienic during transportation. Compared with traditional small bags, it is much more efficient in loading/unloading which helps saving packaging and labor expense as well as logistics cost comprehensively.



Customized Dry Bulk Liner

Customized Dry Bulk Liner is usually provided according to specific cargo features, loading machine in suppliers' factory as well as unloading machine in cargo receivers' facilities.

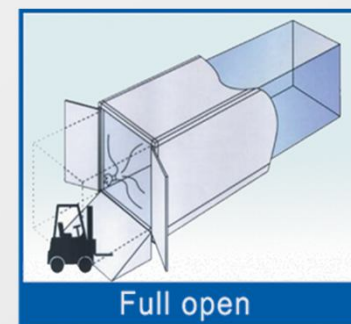
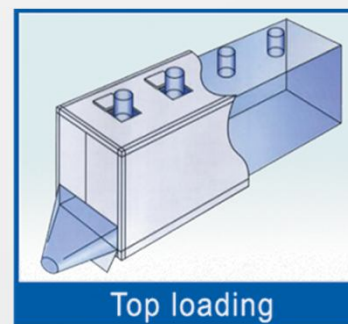
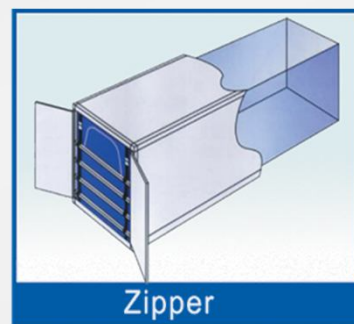
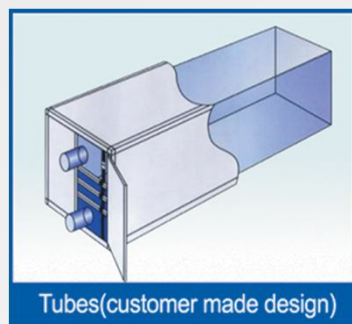

Applicable Products

Food Products



beans, coffee bean, barley, wheat, corn, cocoa powder, flower, milk powder, peanut, hyacinth bean, nut ,pea, rice, salt , seed, starch, sugar, tea, cattle food, etc.

Chemical Products

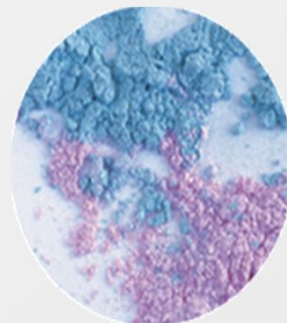

PVC powder, ABS resin, PTA , zinc powder, polyethylene granules, polypropylene granules, nylon polymer, polycarbonate granules, aluminum powder, chemical fertilizer, glass bead, polyester granules, alkaline powder, detergent, porcelain clay, TiO₂ powder etc.

THE LEADING SUPPLIER FOR GLOBAL BULK FLUIDS LOGISTICS AND PACKAGING

➤ Dry Bulk Liner Advantages

Container Liner VS 1000 kg FIBC

Container Space Underutilized



VS



Container Space Utilized Fully

20FIBCs/ 1x20'FCL

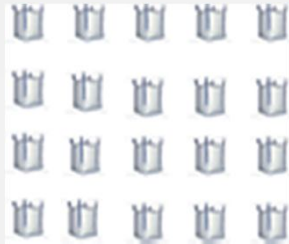

VS



1 Dry Bulk Liner/ 1x20'FCL

High Labor Costs, Low Efficiency



VS



Low Labor costs, High Efficiency

THE LEADING SUPPLIER FOR GLOBAL BULK FLUIDS LOGISTICS AND PACKAGING

Certification



WCA



WIFFA



COA



ISO 9001



FSSC 22000



QS



CRCC



FDA



EC



SKS KOSHER



HALAL

全球散装流体物流包装领导者